

SOUND PERSPECTIVE

SIMPLE & EASY SOUND MASKING

Lencore's Sound Masking System—delivering the highest quality and comfort in SOUND, is simple and efficient. i.Net is also compliant with the National Fire Protection Association's code 72: Fire Alarm and Signaling to shutdown in the event of an emergency (Rack Headend unit only). Because i.Net meets the UL standard for mass notification it is capable of interfacing with a fire alarm control panel and can also reinforce the fire alarm annunciation. Each project is tailored to the client's space, so Lencore ensures that our system is quick and easy to install.

Through our design services, we provide detailed wiring and flow diagrams for product placement. Our headend equipment comes pre-installed in either a rack mountable unit or in a branded enclosure that requires only a power hookup and a Cat 5e cable connection to the system. From there, it is just daisy-chaining speakers and OPs throughout the space.

When installing a Lencore networked solution, the System Manager user interface puts total control in your hands. This innovative controller allows you to adjust the volume and contour for masking throughout the space, adjust volume for paging and background audio, create zones, set EQs, define users of the system, and much more. Technical Support, should you need it, is on-hand by phone or email, ready to address any questions or concerns you may have: support@lencore.com.

Lencore offers a variety of short installation videos that demonstrate the simplicity of our components: headend, OPs, speakers, or install methods. These videos can be found on lencore.com/videos

All sound masking systems can provide speech privacy—that is the easy part. What separates Lencore from the rest is our quality of sound which creates a comfortable work environment. Comfort is the value you and Lencore deliver to the client.

A SOUND MASKING SYSTEM'S ABILITY TO PROVIDE BOTH COMFORT AND SPEECH PRIVACY IS BASED ON:

- The system's ability to produce low frequencies and frequencies within the speech spectrum range.
- The system's ability to mask speech and meet metrics to be the most comfortable.
- Easy to install, tune and balance.
- The system's ability to achieve speech privacy according to all appropriate standards.
- Having a dedicated team to support you.
- Ability to shutdown in the event of an emergency when required by code.
- Headend is UL2572 Listed



Spectra i.Net

PROPOSAL

PEOPLE MATTER. At Lencore, we transform environments that change people's lives by providing more privacy, greater comfort and improved safety. In this proposal we have engineered a system based on your defined needs for sound masking. When designing a sound masking system, two critical criteria must be met: speech privacy and comfort. A well designed sound masking solution allows collaboration and independent work to coexist.

SPEECH PRIVACY

is the science of making conversations less intelligible and distracting; it is the primary purpose for installing a sound masking system. Speech privacy is achieved by raising the ambient background sound to a level slightly above indirect speech, in effect covering or masking the conversation..

COMFORT

may even be considered more important than speech privacy. Fortunately, you do not need to choose between the two. Lencore differentiates itself in the market by producing the most comfortable sound. Five key criteria contribute to a comfortable sound:

- Full Broad Band Sound
- Wrap Around Time
- Multiple Noise Sources
- Uniformity
- Tuning Flexibility

Day to day, building codes exist to keep us safe and to ensure good communication. You should be aware that the National Fire Protection Association Code 72: Fire Alarm and Signaling, requires sound masking to be shut down in the event of an emergency. Not only is i.Net capable of meeting the shutdown sequence, the system can be used to reinforce the fire alarm annunciation. This is possible because the i.Net Headend also meets the UL standard (UL2572) to interface with the Fire Alarm Control Panel - a feature none of our competitors are capable of accomplishing.

The Lencore Spectra i.Net Engineered System Solution for sound masking, paging and audio provides a packaged solution that meets the above criteria, installs easily and is simple to use. Lencore also delivers System Manager, an intuitive graphic user interface which puts the control of the entire system at your fingertips. System Manager is a robust web-based software that allows you to set and manage volume, contour, zone assignments, manage diagnostics and much more, all from the comfort of your PC or smart device.

Lencore has long championed speech privacy and comfort for sound masking. We have been improving the spaces we work in, providing better sound quality, comfort and the user experience with superior systems. Lencore value's the importance of collaboration and concentration. We strive for excellence in all that we do, whether it's educating the market, or engineering the next big thing, our customers are always our priority.

Spectra i.Net (Engineered System Solution)

SYSTEM DESIGN

Basic Install* Daisy chained OP's & daisy chained Speakers from the Headend Enclosure:

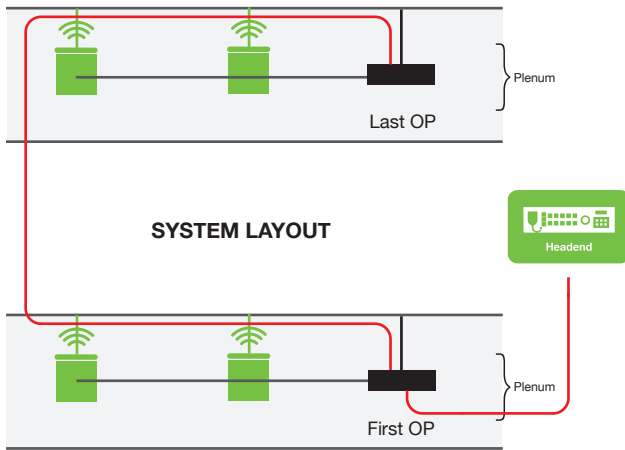

- **Data Cable** connects the headend to the OPs.
- **Speaker Cable** connects OP to each speaker.

**For more detail, see i.Net installation & operations manual*

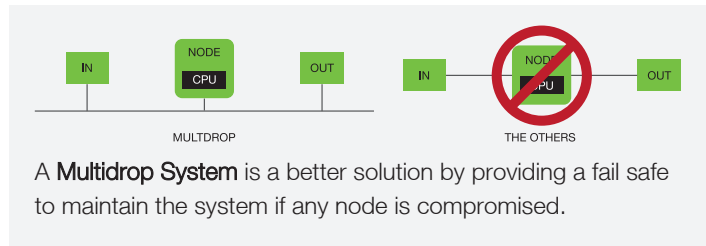

System Manager is a secure, web-based user interface providing a single control point.

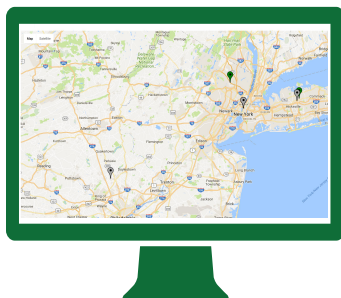

Open Platform Architecture controls and monitors the finished system comes complete with admin and user rights.

**Can be accessed from any desktop or wireless computer with an internet browser, with a username and password.*



- Robust Control Server
- Open-platform interoperable language

SPEECH, PRIVACY AND COMFORT

Speakers (shown above) are used in typical applications. Additional speaker types/hanging mechanisms are available.

UNIQUE CAPABILITIES
i.Net Operating Platform holds up to 32 speakers each. That's eight speakers per channel and four channels. i.Net has two additional audio inputs.

X4

CLOSEOUT DOCUMENTATION

Upon completion of the accepted project, Lencore will ensure that CLOSEOUT DOCUMENTATION is provided. This closeout documentation helps to ensure that all aspects of the project have met the highest level of expectation and that a superior experience was delivered.

THE FOLLOWING WILL BE PROVIDED UPON COMPLETION OF THE PROJECT:

- Installation and Operations Manual.
- System Manager User Guide.
- Spectra i.Net System Installation Checklist.
- Testing and Balancing Checklist.
- Balancing Report as required.
- Checkout and Commissioning Checklist.
- Warranty Certificate.
- As-Built Drawings as required.

This information will be delivered electronically and will also be stored with Lencore in the event that it needs to be referenced in the future. 100% customer satisfaction, 100% of the time. This is one of Lencore's fundamental goals because we believe that every one of our customers deserves superior products and quality experiences.

Thank you for giving Lencore the opportunity to provide the best customer experience possible.